

# OUTDOOR PUMP

## WITH GAUGE



**SARIS**  
INFRASTRUCTURE



The High Security Outdoor Pump offers the highest security features to ensure that the pump and its components are ready for action when its needed by the users. Designed for outdoor use in all climates, this pump is a perfect combination of ruggedness, durability and value and is a great solution for campus, city or other public heavy-use settings.

### Product Specifications

- Outdoor-rated stainless steel construction, completely sealed
- Proprietary long-life piston seal and solid pump rod
- Steel braided air hose core prevents cutting
- Includes all-metal High Performance Pump Head with Presta and Schrader Valves
- Longer hose available with mounting clip
- Optional tools attached by stainless steel aircraft cable: (2) tire levers and (1) 15mm open end wrench
- 2 year warranty

# Outdoor Pump with Gauge

## Recommended Setbacks

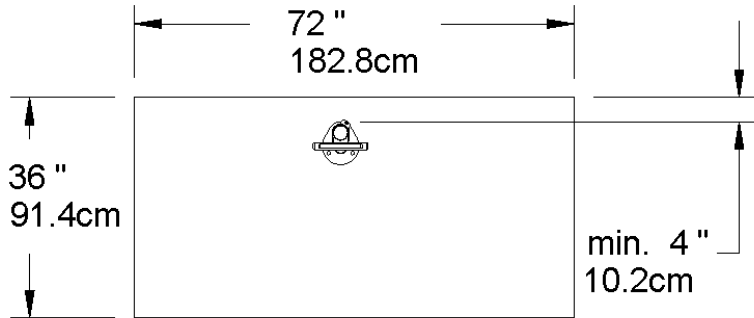

The minimum space requirements for High Security Bike Pumps are meant to allow a cyclist and their bike access to the pump.



Installation hardware included



Stainless Steel



Stainless Steel



2 year warranty



Made in the USA

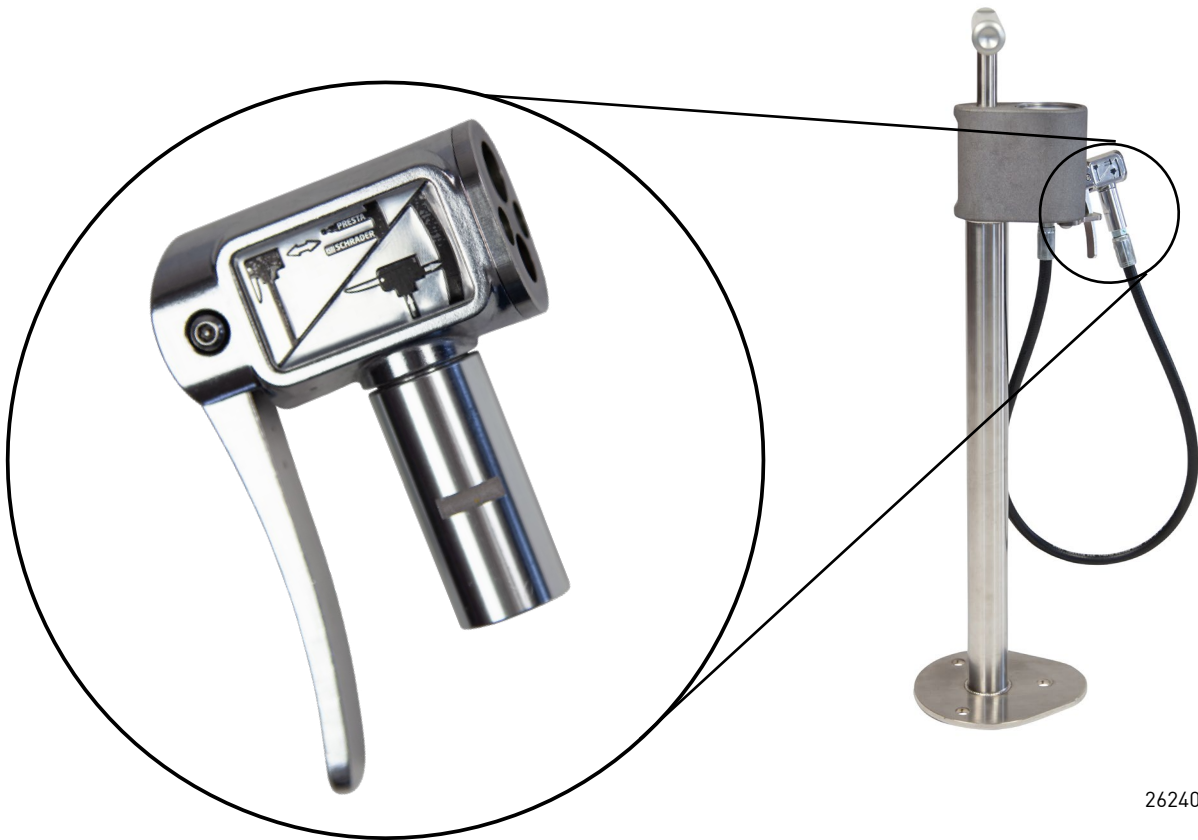

26240 Shown

### Dimensions

Model #	Description	Type of Mount	Weight	Length	Width	Height	Space Requirement
26240	Short Hose	Floor	20 lbs.	8"	8"	30"	See Back
26246	Long Hose	Floor	20 lbs.	8"	8"	30"	See Back
26242	Long Hose	Repair Stand	20 lbs.	8"	8"	30"	See Back

Our Saris Infrastructure representatives can assist with custom layout and spacing to meet your room dimensions and desired bike capacity.

Saris Infrastructure 800.783.7257

www.sarisinfrastructure.com

Downloadable product resources available online:



CAD Files



SketchUp Files



Written Specs



Photos