

INDOOR PUMP

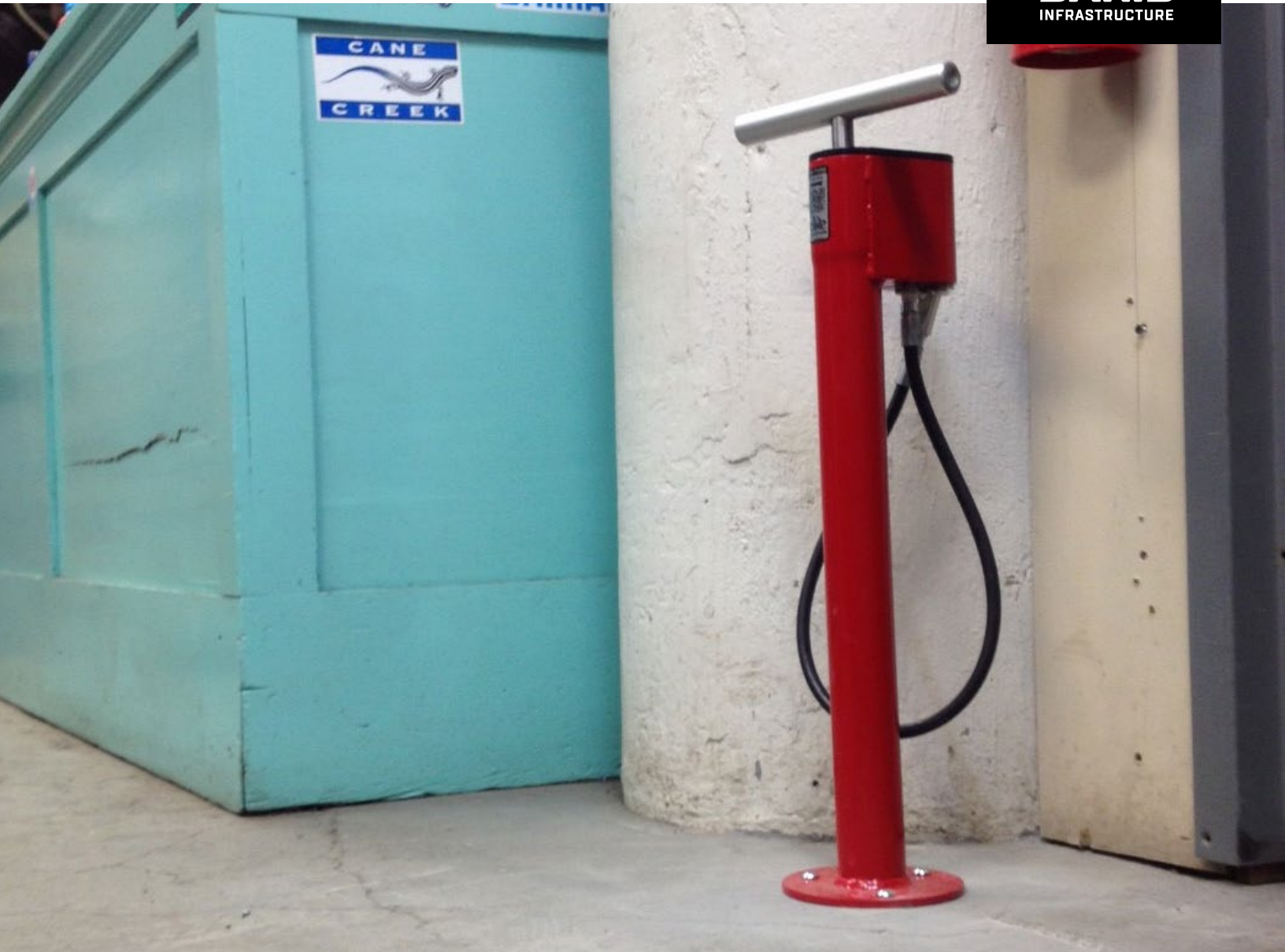

The High Security Indoor Pump is a perfect shared-use bike pump for inside installation. It is ideal for bike rooms and parking areas. A high quality, solid stainless steel piston rod, alloy handle and smash proof gauge cover provide maximum vandal resistance and durability. Heavy duty, cut-resistant hose and security fittings hold a replaceable pump head that handles both Presta and Schrader valves with ease.

Product Specifications

- Solid stainless steel piston rod, alloy handle, and smash proof gauge cover provide maximum vandal resistance
- Hose with braided steel core provides protection against cutting
- Choice of two hose lengths (18" or 35")
- Includes all-metal High Performance Pump Head with Presta and Schrader Valves
- 2 year warranty

Indoor Pump

Recommended Setbacks

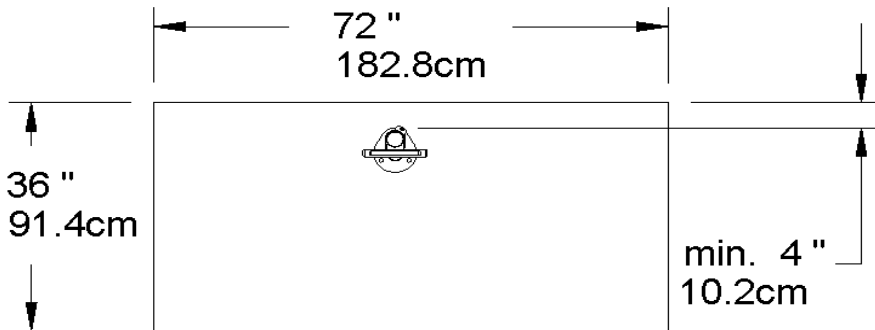

The minimum space requirements for High Security Bike Pumps are meant to allow a cyclist and their bike access to the pump.



Installation hardware included



Body: Formed steel housing; DOM tubing
Hose: Rubber exterior; Braided steel core



Powder coat



2 year warranty



Made in the USA



Standard Colors

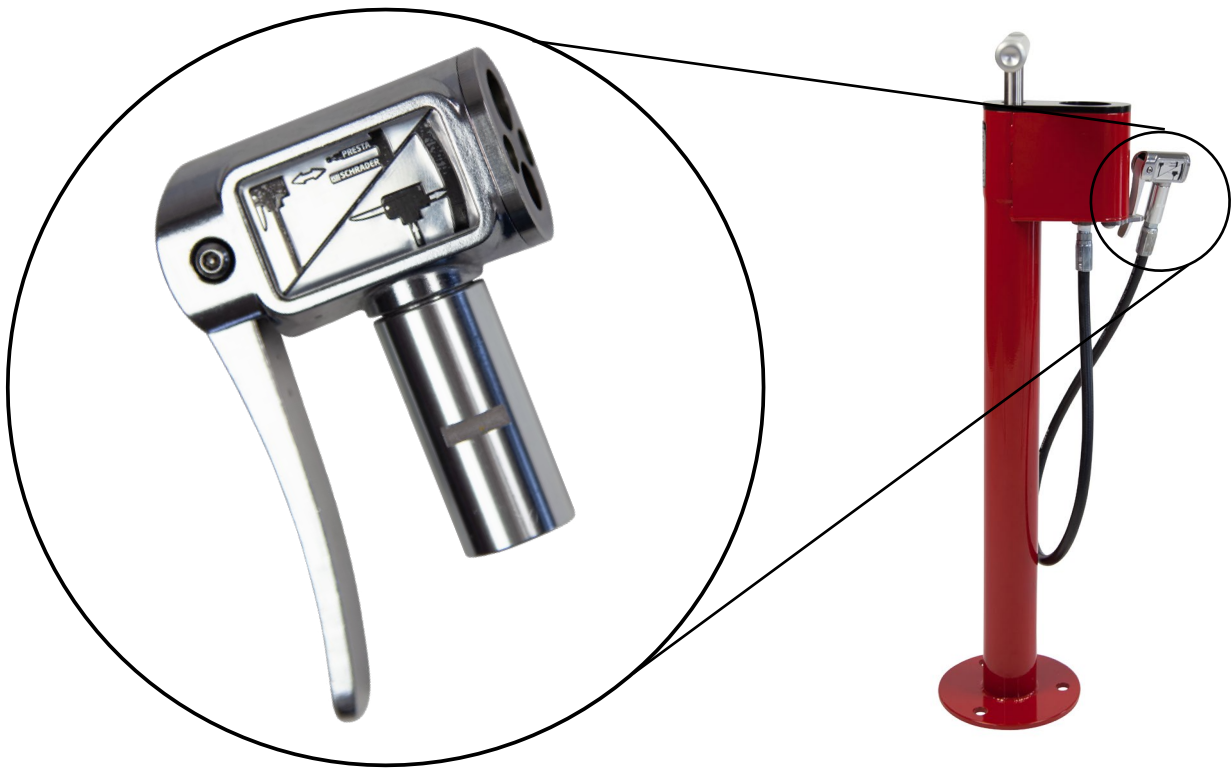

26248 Shown

Dimensions

Model #	Finish	Type of Mount	Weight	Length	Width	Height	Space Requirement
26248	Powder Coat	Flange	20 lbs.	8"	8"	30"	See Back
26252	Powder Coat	Repair Stand	20 lbs.	8"	8"	30"	See Back

Our Saris Infrastructure representatives can assist with custom layout and spacing to meet your room dimensions and desired bike capacity.

Saris Infrastructure 800.783.7257

www.sarisinfrastructure.com

Downloadable product resources available online:



CAD Files



SketchUp Files



Written Specs



Photos